



DMX1602 DMX-512 DECODER

DMX-512 decoder conforming to USITT DMX512/1990 and DMX512/1986 Standards.

Addressing: Can be set to start anywhere within 512 channels. Multiple cards can be used without channel overlap.

Digital Outputs: 16 digital with open collector transistors rated 50VDC, 250mA per channel maximum. Selectable for TTL-compatible outputs. Selectable switching logic polarity.

Analog Outputs: 2 analog outputs, adjustable gain for 0-5 VDC or 0 to 10 VDC

Power Supply: 12VDC @ 50mA minimum

DMX1602 DMX-512 DECODER

The LOGIC SYSTEMS DMX1602 decoder card decodes a standard DMX-512 signal into 18 channels. Channels 1-16 are open collector NPN digital outputs. SIP resistor packs can be plugged into the empty sockets to configure the outputs for TTL/CMOS compatibility. Channels 17 and 18 are analog outputs. The card can be used anywhere within the DMX-512 controller channel group. The starting address is set via dip switches. The digital output switching polarity can also be programmed. The DMX start code for the decoder card is zero. Multiple cards can be used with no overlapping of channels. In the event of a DMX-512 signal loss the outputs will remain at their last state.

ADDRESSING

The decoder card uses base-zero addressing. When dip switches 1 through 9 are OFF the first card channel will be DMX controller channel 1.

Example:

To set the starting address to 342 set dip switches as follows.

Set DIPSWITCH SW1 switches to the following:

SW9	SW8	SW7	SW6	SW5	SW4	SW3	SW2	SW1
256	128	64	32	16	8	4	2	1
on	-	on	-	on	-	on	-	on
-	on	-	on	-	on	-	on	-

To get the starting address add up the values of the switches that are on. We have base-zero addressing so add one more. Our starting address is $256+64+16+4+1+1=342$. The card will use DMX-512 channels 342 through 359

POWER SUPPLY

The decoder card requires a 12VDC power supply. Connect to connector P1. See Figure 1 for pinout. The card requires 50 mADC minimum. Add the accessory power requirements when sizing the power supply.

DIGITAL OUTPUTS

Connector P3 outputs the card channel 1 through 16 digital outputs, +12 VDC accessory power and common. The outputs are open collector transistor outputs. Dip switch 10 determines how the outputs will switch. When dip switch 10 is OFF the output transistors will switch ON when the assigned DMX channel is above 50% and will switch OFF if below 50%. When dip switch 10 is ON the opposite switching will occur. The decoder card can output TTL/CMOS compatible signals by installing RN3 and RN4 in their respective sockets. RN3 is an 8 pin 2.2K Ω resistor network and RN4 is a 10 pin 2.2K Ω resistor network.

CONNECTOR P3 PINOUT

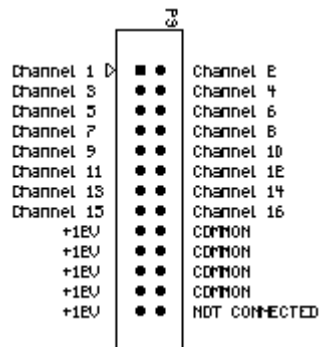

ANALOG OUTPUTS

Connector P8 outputs channels 17 and 18 analog outputs. They are factory adjusted to 0-10 VDC. The outputs can be adjusted down for a 0-5 VDC output range. Trimmer R5 adjusts channel 18 gain and trimmer R2 adjusts channels 17 gain. Counter-clockwise adjustment will lower the gain. +12 VDC is provided on the connector for accessory power. The +12VDC current availability is dependent on the power supply used. See Figure 1 for connector pinout.

DMX512 SIGNAL INPUT

Connector P2 accepts a USITT/1986 or USITT/1990 standard DMX-512 signal input. See Figure 1 for connector pinout. Any other signal will give unknown results. Jumper J1 connects the terminating resistor and is used when the card is the last one on the cable run.

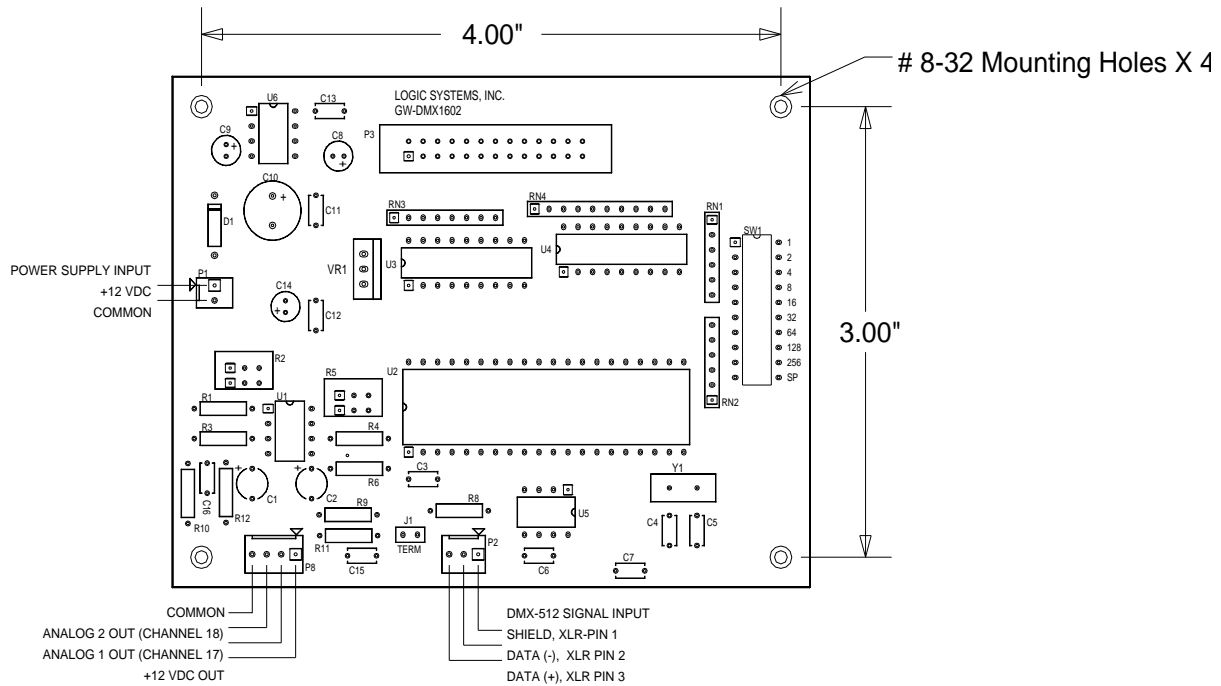

FIGURE 1



RLY16

The Logic Systems, Inc. RLY16 converts the DMX1602 16 digital outputs to high voltage, high current isolated relay contacts. Designed to be used with the DMX1602 DMX-512 decoder card.

DIGITAL INPUTS

Connector P3 inputs the card channel 1 through 16 digital outputs from the DMX1602 decoder card, and +12 VDC card power. To energize the relay, connect the selected channel to power supply common.

CONNECTOR P3 PINOUT

PIN 1 - CHANNEL 1	PIN 2 - CHANNEL 2
PIN 3 - CHANNEL 3	PIN 4 - CHANNEL 4
PIN 5 - CHANNEL 5	PIN 6 - CHANNEL 6
PIN 7 - CHANNEL 7	PIN 8 - CHANNEL 8
PIN 9 - CHANNEL 9	PIN 10 - CHANNEL 10
PIN 11 - CHANNEL 11	PIN 12 - CHANNEL 12
PIN 13 - CHANNEL 13	PIN 14 - CHANNEL 14
PIN 15 - CHANNEL 15	PIN 16 - CHANNEL 16
PINS 17, 19, 21, 23, 25 - +12VDC IN	PINS 18, 20, 22, 24, 26 - NOT CONNECTED

RELAY OUTPUTS

The RLY16 accessory card has 16 isolated SPST normally open high voltage, high current contacts. They are rated up to 3 AMPS @ 220 VAC. The contacts do not have on board fuses.

P4 - 1, 2 - Relay 1	P5 - 1, 2 - Relay 5
P4 - 3, 4 - Relay 2	P5 - 3, 4 - Relay 6
P4 - 5, 6 - Relay 3	P5 - 5, 6 - Relay 7
P4 - 7, 8 - Relay 4	P5 - 7, 8 - Relay 8
P6 - 1, 2 - Relay 9	P7 - 1, 2 - Relay 13
P6 - 3, 4 - Relay 10	P7 - 3, 4 - Relay 14
P6 - 5, 6 - Relay 11	P7 - 5, 6 - Relay 15
P6 - 7, 8 - Relay 12	P7 - 7, 8 - Relay 16

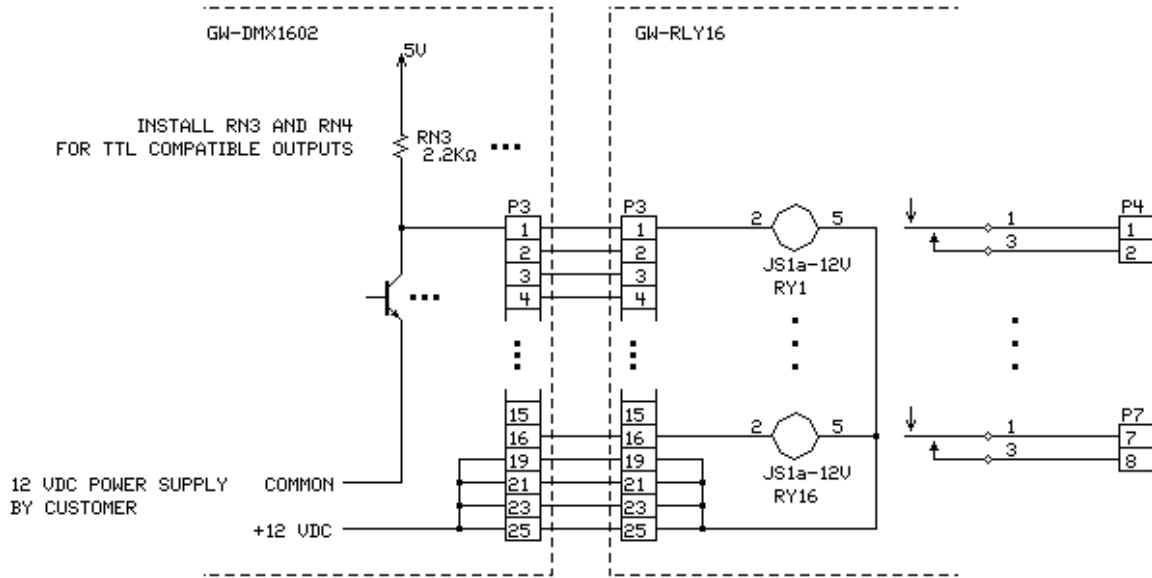
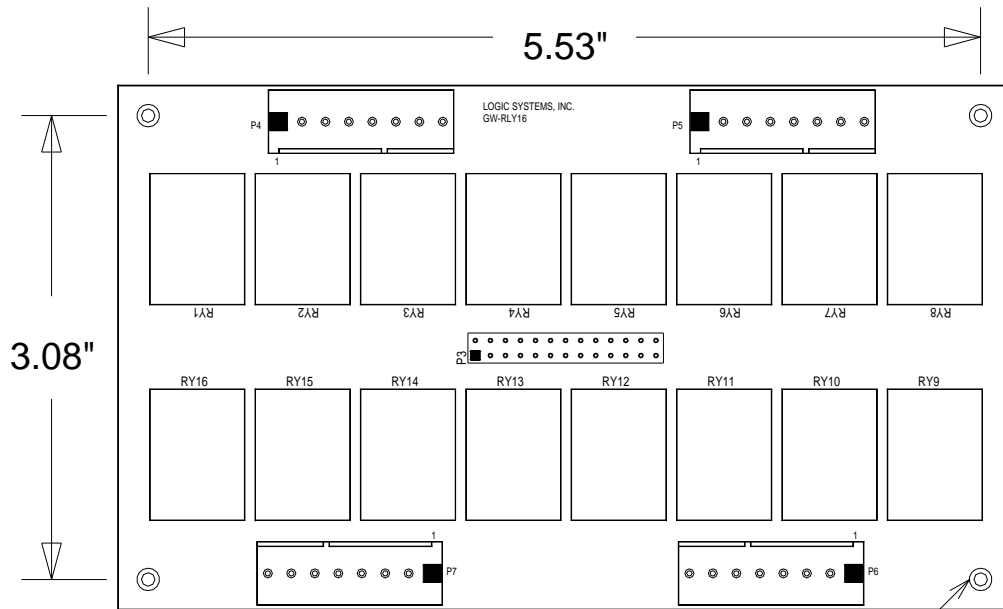

FIGURE 1



8-32 CLEARANCE HOLE X 4

FIGURE 2